

Road and Rail Department
Railway
Railway Engineering

Supplementary information National rules for railway vehicles interaction with Swedish railway infrastructure and other vehicle functions

Date
30 June 2023

 Version
7.0

 Reference
TSG 2015-185

Version history

Version	Date	Description	Person responsible
1.0	2015-02-10	New document based on TS JV 2009:003	Robert Bylander
1.1	2015-08-21	New names on documents from Trafikverket	Robert Bylander
2.0	2015-09-22	Reference document [15] deleted	Robert Bylander
3.0	2020-06-11	Adaption to notified national rules	Robert Bylander
4.0	2021-04-14	Change in 3.2 I, 5.2 I, 5.10.10 4B and 4F, 5.10.12 C	Robert Bylander
5.0	2021-10-15	New template with other numbering of chapters and accessibility adjustment. Change in 4.4, 4.8 G,H, 6.4	Robert Bylander
6.0	2022-06-01	Adaption to regulation with national rules for railway vehicles (TSFS 2022:36). Profile G2 added in 4.6, 5.4 and 6.6. Clarification in 4.4 and 6.4. Information about running dynamics for three-axle vehicles inserted in 4.5, 5.3 and 6.5. Information about TDOK 2014:0774 inserted in 4.8.	Robert Bylander
7.0	2023-06-30	Inserted reference to list of data to be sent to Swedish Transport Administration in 4.8. Inserted explanatory text to 1 – 8 §§ in TSFS 2022:36. Additional text about “special reasons” at severe winter conditions.	Robert Bylander

Content

EXPLANATIONS OF TERMS AND ABBREVIATIONS.....	5
1 PURPOSE.....	6
2 SCOPE.....	7
3 TARGET GROUP	7
4 LOCOMOTIVES AND PASSENGER VEHICLES.....	7
4.1 Detectability in terms of signal safety	8
4.2 Interaction with train protection systems	9
4.3 The infrastructure scanning for railway vehicles.....	12
4.4 Communication between the railway vehicle and traffic management .	12
4.5 Dynamic interaction with the track.....	13
4.6 Dynamic and static profile.....	13
4.7 Electromagnetic compatibility with the environment excluding energy .	13
4.8 Current collection and interaction with the infrastructure energy system.....	14
4.9 Towing, lifting/rescue	15
4.10 Other vehicle functions	16
4.10.1 Vehicles' safety in railway tunnels.....	16
4.10.2 Vehicle design for severe winter conditions	16
5 FREIGHT WAGONS.....	17
5.1 Detectability in terms of signal safety	18
5.2 The infrastructure scanning for railway vehicles.....	19
5.3 Dynamic interaction with the track.....	20
5.4 Dynamic and static profile.....	20
5.5 Electromagnetic compatibility with the environment excluding energy .	20
5.6 Towing, lifting/rescue	21
5.7 Other vehicle functions	21
5.7.1 Vehicle design for severe winter conditions	21
5.7.2 Vehicle structure and mechanical parts	22
5.7.3 Couplings.....	22
5.7.4 Strength of bogie frame.....	22
5.7.5 Wheel sets, wheels and axles	23
5.7.6 Brake system and brake performance	23
6 OTMS AND SHUNTERS	24
6.1 Detectability in terms of signal safety	24
6.2 Interaction with train protection systems	26
6.3 The infrastructure scanning for railway vehicles.....	28
6.4 Communication between the railway vehicle and traffic management .	29
6.5 Dynamic interaction with the track.....	29

6.6	Dynamic and static profile.....	30
6.7	Electromagnetic compatibility with the environment excluding energy .	30
6.8	Current collection and interaction with the infrastructure energy system.....	30
6.9	Towing, lifting/rescue	30
6.10	Other vehicle functions	31
6.10.1	Vehicle design for severe winter conditions	31
6.10.2	Vehicle structure and mechanical parts	32
6.10.3	Couplings.....	32
6.10.4	Strength of bogie frame.....	32
6.10.5	Wheel sets, wheels and axles	33
6.10.6	Windscreen.....	34
6.10.7	Brake system and brake performance	34
6.10.8	Fire safety.....	35
6.10.9	Driver's cab.....	35
6.10.10	External lights & visible and audible warning devices.....	36
6.10.11	Radio remote for shunting operation	39
6.10.12	Noise	39
7	REGULATION TSFS 2022:36 §§ 1 – 8.....	41
7.1	TSFS 2022:36 §§ 1 – 3, scope	41
7.2	TSFS 2022:36 §§ 4 – 5, Rebuilding and modernisation.....	42
7.2.1	Vehicles in the scope of TSI Loc&Pas or TSI WAG.....	42
7.2.2	OTMs and freight wagons that are authorised according to national requirements.....	43
7.3	TSFS 2022:36 §§ 7 – 8, Verification procedure	43
7.3.1	Assessment	43
7.3.2	Documentation	44
8	ADMINISTRATION	44
9	REFERENCES.....	44

Explanations of terms and abbreviations

ATC2	Swedish/Norwegian Automatic Train Control system of class B for vehicles and track side
ATCR	Swedish Automatic Train Control system of class B for vehicles and track side for the radio block Linköping-Västervik/Kisa
CSM-RA	COMMISSION IMPLEMENTING REGULATION (EU) No 402/2013 of 30 April 2013 on the common safety method for risk evaluation and assessment and repealing Regulation (EC) No 352/2009
ERA	European Union Agency for Railway
ETCS	European Train Control System (Joint European train control system intended to replace ATC2)
GSM-R	Digital mobile telephone network adapted for railways
SS-EN	Swedish and European standard
STM	Specific Transmission Module (used along with ETCS in operation of tracks with ATC-2)
TDOK	Document (standard) from Trafikverket
CCS TSI	Commission regulation (EU) 2016/919 of 27 May 2016 on the technical specification for interoperability relating to the ‘control-command and signalling’ subsystems of the rail system in the European Union
Loc&Pas TSI	Commission regulation (EU) No 1302/2014 of 18 November 2014 concerning a technical specification for interoperability relating to the ‘rolling stock — locomotives and passenger rolling stock’ subsystem of the rail system in the European Union
WAG TSI	Commission regulation (EU) No 321/2013 of 13 mars 2013 concerning the technical specification for interoperability relating to the subsystem ‘rolling stock — freight wagons’ of the rail system in the European Union and repealing Decision 2006/861/EC
Road-rail vehicle	Railway vehicle which, when not running on rails, is a vehicle under the Road Traffic Definitions Act (2001:559)
Automatic Train Control system	System which ensures that a railway vehicle does not exceed the permitted speed, and which displays the permitted speed to the driver

1 Purpose

Vehicles for the Swedish part of the European Union's railway system

This supplementary information should be read in conjunction with the Swedish Transport Agency's regulations and general recommendations on railway vehicles (TSFS 2022: 36), where there are technical requirements on for railway vehicles that are to operate in the Swedish part of the European Union's railway system. The document should be seen as a compilation and a guidance on how the compatibility between railway vehicles and the infrastructure or other safety of vehicles can be achieved and then certified in the authorisation process. The requirements must be reviewed by a designated body (DeBo). For a temporary approval, the designated body's report shall include statements as to whether or not the vehicle achieves what is described and a list of documents on which the review is based. If the vehicle does not achieve this, the deviation must be described. The designated body may propose restrictions that must apply in order for the vehicle to be operated safely. These terms/restrictions must be analysed and managed by the applicant. An review assignment can include one or more of the functional areas that apply to the vehicle type in question - several different designated bodies can thus be hired.

When vehicles have been rebuilt, the latest applicable TSI must be followed, if applicable. The review of these vehicles need only include requirements concerning the rebuilt parts and their interfaces. Review does not need to be done after repairs or maintenance measures.

This supplementary information does not include documents relating to the Danish part of the infrastructure managed by Øresundsbro Konsortiet. Review relating to switching between Danish and Swedish train radio, switching between Danish and Swedish ATC, tunnel conditions and other specific Danish conditions is carried out upon authorisation for the Danish part of the infrastructure managed by Øresundsbro Konsortiet.

Vehicles for national railway systems

The Swedish Transport Agency's regulations on authorisation of railway vehicles for national railway systems (TSFS 2022:34) contain provisions on authorisation of railway vehicles. According to the authorisation regulation, the Swedish Transport Agency requests documentation certifying the safety of the railway vehicle. The Swedish Transport Agency requires that the inspection be carried out by an external competent party who must be approved by the Swedish Transport Agency.

This supplementary information contains a compilation of descriptions of how railway vehicles achieve safe interaction with Swedish railway

infrastructure as well as references to related documents. There are also described features in areas other than those that affect compatibility with the infrastructure.

The report submitted by the external reviewer shall contain statements as to whether the vehicle achieves what is described or not, as well as a list of the documents on which the examination is based. If the vehicle does not achieve this, the deviation must be described. The external reviewer may propose restrictions that must apply in order for the vehicle to be operated safely. These terms/restrictions must be analysed and managed by the applicant. An review assignment can include one or more of the functional areas that apply to the current vehicle type - several different external reviewers can thus be hired.

2 Scope

The document is valid for vehicles that are in the scope of Directive 2016/797 and thus the Swedish Transport Agency's regulations on authorisation of railway vehicles for the Swedish part of the European Union's railway system (TSFS 2022:35). It is also applicable to vehicles that are authorised in accordance with the Swedish Transport Agency's regulations on authorisation of railway vehicles for national railway systems (TSFS 2022:34) and that will operate the Swedish Transport Administration's infrastructure or infrastructure that is connected to the Swedish Transport Administration's infrastructure. It is also applicable to other vehicles in applicable parts, especially those parts that do not concern the infrastructure.

3 Target group

The document is aimed at those who need to know the requirements for getting new and rebuilt vehicles authorised in Sweden, as well as the independent reviewers who shall review whether vehicles meet the requirements (Notified bodies, Designated bodies, Assessment bodies CSM-RA and external reviewers).

4 Locomotives and passenger vehicles

Applicable requirements for locomotives and passenger vehicles complying with TSIs

When authorising locomotives and passenger vehicles that have been assessed by a notified body and complies with the Loc&Pas TSI, only

4.10.1 and 4.10.2 A need to be applied. If the vehicle has a train protection system, then 4.2 shall also be applied.

Applicable requirements for locomotives and passenger vehicles that have an authorisation from a foreign country

When authorising locomotives and passenger vehicles that have an authorisation from another EU + NO / CH Member State (but not assessed by a notified body against the Loc&Pas TSI), only requirements 4.10.1 B and 4.10.2 need to be applied in addition to the requirements to demonstrate compatibility with the infrastructure, 4.1 - 4.9, see chapter 7.1.

4.1 Detectability in terms of signal safety

The vehicle must comply with the applicable parts of document ERA/ERTMS/033281 [1], and the requirements below.

- A. The distance between two successive axles must be no more than 17.5 metres (a_3 i figure 4.1) However, the distance may be up to 20 metres if the vehicle is only used on such infrastructure that is technically compatible with such a distance between the axles.
- B. The distance between the first and last axle shall be at least 4.5 metres ($L - b_1 - b_2$ in figure 4.1). However, the distance may be down to 3 metres if the vehicle is only used on such infrastructure that is technically compatible with such a distance between the axles.

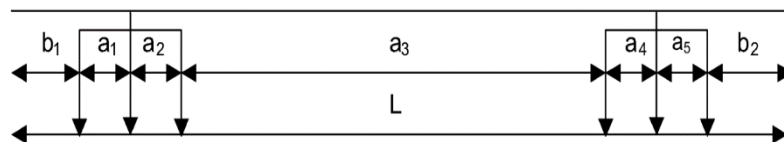

Figure 4.1. Distances between axles

- C. The distance from the outermost axle to the end of the vehicle including buffers may not exceed 4.2 metres.

Half-width of a vehicle including end-throw outward (df) in a curve with a radius of 190 metres may not be larger than the following (where "bi" is the distance from the outermost axle to the vehicle's dimensioning cross section):

$$df \leq 1,93 - 0,206 (b_i - 2,50) \text{ when } 2,50 < b_i \leq 4,20 \text{ m}$$

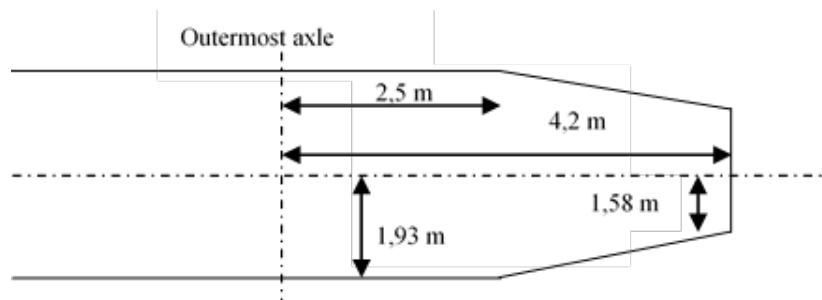

Figure 5.2 Maximum vehicle width including end-throw outside outermost axle.

See also reference [2].

- D. The inrush current shall not exceed 25.0 A measured in the frequency range 0.0-2.0 Hz. During the connection process, the DC component in the inrush current may exceed 45.0 A for a maximum of 1.5 seconds, and it may exceed 25.0 A for a maximum of 2.5 seconds. The currents shall be measured for each combination or multiple of vehicles. The inrush current shall be verified according to TDOK 2014:0774 [3], annex 1 section 3.2.1.
- E. The electrical resistance between the running surfaces of the opposite wheels of a wheelset shall not exceed 0.05 Ω , measured with a voltage between 1.8 V and 2.0 V. The electrical resistance between the running surfaces of the opposite wheels of a wheelset shall be verified according to the method described in TDOK 2014:0776 [4].
- F. The minimum axle load shall be 30 kN for vehicles with brakes acting on the wheels' wear surfaces and 50 kN for other vehicles.

4.2 Interaction with train protection systems

Locomotives and multiple units shall be equipped with an on-board train protection system that is compatible with at least one of the following systems:

1. The track-side part of ATC2 or ATCR (system with radio block function).
2. An ETCS type track-side train protection system according to CCS TSI.

Vehicles with installed ETCS shall meet the CCS TSI. In addition for installation of ETCS as well as installation of ATC2/ATCR the requirements A – J below shall be fulfilled in applicable parts. For

installations of ATC2 a description of how the requirements can be assessed is found in Transportstyrelsen's guideline "ATC-installationer i fordon" [5].

- A. The on-board ETCS train protection system shall have at least 30 000 operating hours on average between failures (MTBF) that requires isolation of the train protection functions. This shall be shown by a calculation based on accepted methods for operational safety calculation.
- B. For vehicles equipped with type ETCS baseline 2, it shall be shown that
 1. the braking curves described in the European Union's Railway Agency document 'Description of the brake curve calculation, EEIG 97E881 version 7A' [6] are implemented in the system, and
 2. the system has a monitor according to the current specification for baseline 3 in the European Union's Railway Agency document 'ETCS Driver machine interface, ERTMS 015560', v3.4.0 or v3.6.0 [7].
- C. For vehicles equipped with ETCS and radio remote control, it shall only be possible to use the radio remote control when ETCS on board is in shunting operation mode.
- D. A vehicle equipped with ATC2, ATCR or with STM function shall have a safety case showing that the onboard system is safely integrated in the vehicle. This safety case shall at least include that the onboard system:
 1. has been installed correctly based on the conditions for installation of equipment according to the manufacturer's specification,
 2. has characteristics and functions that are compatible with the track-side part of ATC2 and/or ATCR.
- E. The STM function shall have features and functions that are compatible with the track-side part of ATC2. It shall be shown that the functional requirements have been developed using the methods described in standards SS-EN 50126, SS-EN 50128 and SS-EN 50129. An STM function intended for ETCS baseline 3 shall meet the requirements of Transportstyrelsen's document STM FRS BVS 544.65001 [8], version 6.1, and STM GRS 100200 E004 TR GRS [9], version 6.1.

- F. A vehicle's interface between the ATC2, ATCR system or the STM function and its service braking system shall be risk assessed in accordance with Annex 1 to CSM-RA. In the risk assessment, the severity level shall be considered critical for the risk that an error or a combination of errors will cause a delay of emergency braking if the service brake is already activated.

The risk shall be considered as being taken care of if it can be shown that the service brake system, including feedback from the brake to the STM function or the ATC2, ATCR system, has a failure rate of no more than 1×10^{-6} errors per operating hour.

- G. A vehicle equipped with an ATC2, ATCR type train protection system or with an STM function must meet the following requirements for safe integration into the vehicle:
1. Traction disconnection shall occur when the ATC2, ATCR system or STM function orders brake.
 2. Back feed of the brake must not take place during brake intervention from the ATC2, ATCR system or the STM function.
 3. If the vehicle has a performance that makes it possible to accelerate more than 1.5 m/s^2 , there must be an acceleration limitation of at most 1.5 m/s^2 .
 4. There must be a brake feedback signal from the braking system to the ATC2, ATCR system or the STM function. This signal shall be activated by brake intervention due to a pressure drop or a reaction in a brake relay.
- H. The error rate of the STM function shall be less than or equal to 1×10^{-9} error/operating hour for errors that may cause a vehicle speed higher than what the track-side part of ATC2 allows. This shall be shown by a calculation based on accepted methods for calculating acceptable frequencies for safety-critical errors.
- I. The STM function shall have the same functions as the on-board ATC2 system. Deviations or functions that have not been implemented shall be handled in accordance with (EU) 402/2013 CSM-RA either by comparison with reference system or by code of practice so that operational safety is not impaired.
- J. Analyses and tests shall show that the STM function and the track-side part of ATC2 are compatible based on
1. any deviations, restrictions and conditions of the subsystems, as well as

2. the transitions between different types or versions of track-side train protection systems.

4.3 The infrastructure scanning for railway vehicles

A vehicle must be able to be detected by track-side equipment for axle bearing condition monitoring according to A or be equipped with on-board equipment for axle bearing condition monitoring according to B.

- A. The target area of the vehicle that the track-side equipment is to detect shall be according to Table 4.1. The same applies to the area of the vehicle that shall be free from other heat sources so as not to disturb the detection. Definitions of the parameters in the table shall be according to the standard SS-EN 15437-1:2009 (repealed and replaced by SS-EN 15437-1:2009+A1:2023).

Table 4.1 Target area and area free from other heat sources. The dimensions in the table are given in millimetres.(System 1 = "Servo" and system 2 = "Fues")

Type of track-side equipment	Y_{TA}	W_{TA}	L_{TA}	Y_{PZ}	W_{PZ}	L_{PZ}
System 1	862	≥ 40	Whole	862	≥ 60	≥ 500
System 2	905 ± 20	≥ 40	Whole	905	≥ 100	≥ 500

The requirements on how the vehicle shall be designed for detectability are also described in TDOK2014:0690 [10].

- B. On-board equipment for axle bearing condition monitoring shall be able to detect deteriorations on all of the vehicle's axle bearings and indicate them to the driver.

4.4 Communication between the railway vehicle and traffic management

A vehicle with cab shall have a train radio of type GSM-R, which is permanently installed with an external antenna according to specifications in CCS TSI. The train radio shall fulfil GSM-R Baseline 1 according to CCS TSI.

The requirement is that there shall be GSM-R and that it shall fulfil Baseline 1. This requirement shall be reviewed by a designated body. The requirements on the phone and its installation, testing included, is in the CCS TSI. Requirements in the TSI are reviewed by notified bodies.

4.5 Dynamic interaction with the track

A vehicle's running dynamic behaviour shall be ensured by applying the standard SS-EN 14363:2016 (repealed and replaced by SS-EN 14363:2016+A2:2022) or by the vehicle's in-service experience from a state within the EEA or from Switzerland on infrastructure with a track gauge width of 1 435 millimetres.

To ensure the running dynamic behaviour of locomotives with the maximum permissible axle load above 225 kN and up to 350 kN, the Swedish Transport Administration's standard TDOK 2016:0508 [11] shall be applied.

When changing the running dynamic properties for three-axle locomotives with short wheelbase, analyses should be made that show how the locomotive is affected by track errors at level crossings, see reference [15].

4.6 Dynamic and static profile

The conformity of a vehicle with a reference profile shall be determined according to one of the methods specified in the standard SS-EN 15273-2:2013 (repealed and replaced by SS-EN 15273-2:2013+A1:2016) or by another equivalent method. The vehicle profile must comply with the requirements for dynamic profile SEa or SEc in SS-EN 15273-2:2013 (repealed and replaced by SS-EN 15273-2:2013+A1:2016) or static profile A or C in TDOK 2015:0143 [12]. For vehicles with profile NO1, G1, GA, GB or GC according to SS-EN 15273-2:2013 (repealed and replaced by SS-EN 15273-2:2013+A1:2016) the following apply.

- NO1, G2, G1, GA, GB are housed in Swedish profile SEa.
- GC is housed in Swedish profile SEc.

Specifically for infrastructure managed by Øresundsbro Konsortiet

The vehicle profile must comply with the requirements for GC profiles in SS-EN 15273-2:2013 (repealed and replaced by SS-EN 15273-2:2013+A1:2016). Vehicles with Swedish profile A or SEa fulfil that requirement.

4.7 Electromagnetic compatibility with the environment excluding energy

The vehicle must comply with SS-EN 50121-3-1, SS-EN 50500 and SS-EN 62311. These requirements belong to the Directive of EMC and are not assessed at authorisation. However, conformity shall be stated in the EC declaration of verification.

Additional requirements for vehicles with pantographs are to be found in chapter 4.8. Vehicles without pantograph shall fulfil requirements for protection against electric shock according to SS-EN 50153.

4.8 Current collection and interaction with the infrastructure energy system

An electrical vehicle shall be designed for a nominal voltage of 15 kV, 16 $\frac{2}{3}$ Hz and meet requirements A – I below.

If the vehicle is intended for traffic on the Öresund bridge connection, it shall also be designed for a nominal voltage of 25 kV, 50 Hz. These requirements are described in Trafik-, bygge- og boligstyrelsens ”Bekendtgørelse om køretøjers tekniske kompatibilitet med jernbanenettet” [13]. Safe switching between Danish and Swedish energy systems shall be proven.

- A. The voltage that a vehicle returns to the overhead contact line, U_{max2} , when using the regenerative brake may not exceed 17.5 kV. The voltage that a vehicle returns to the overhead contact line when using the regenerative brake shall be verified according to the standard SS-EN 50388:2012, Section 12.1.1, the standard SS-EN 50163:2004, Section 6.1 and the standard SS-EN 50215:2009, Section 9.15.
- B. A vehicle with a power greater than 2 MW must be provided with a power or current limitation function. This includes fixed and predefined formations. The vehicle must also be equipped with automatic regulation that limits the current to the greatest current in relation to voltage according to the standard SS-EN 50388:2012.
- C. A vehicle must not cause overvoltage or other disturbances in the overhead contact line as described in Section 10.1 of the standard SS-EN 50388:2012. A compatibility study shall be conducted according to the method indicated in Section 10.3 of the standard.
- D. The width of a vehicle’s pantograph head shall be 1 950 or 1 800 millimetres. The geometric design of a pantograph head with the width 1 950 millimetres shall be according to the standard SS-EN 50367:2012, Annex A.2.2. If the width is 1 800 millimetres, the geometric design shall be according to Annex B.2, Figure B.5.
- E. A vehicle’s pantograph shall be installed in such a way that it can have mechanical contact with at least one of the contact wires that lie 4 800-6 100 millimetres above rail level.

- F. A pantograph's contact strip shall be of plain carbon or of impregnated carbon with additive material. If a metallic additive material is used, it shall consist of copper or of a copper alloy. The metal content must not exceed 35 % by weight.
- G. A pantograph's static contact force shall be $55 \text{ N} \pm 10 \%$. However, the contact force may be 70 N in vehicles that are only used on such infrastructure that is adapted for that contact force.
- H. A pantograph's dynamic contact force, F_{mean} , shall be in the interval
1. $(0,00047 \times v^2) + 55 \text{ N}$ to $(0,00097 \times v^2) + 55 \text{ N}$, or
 2. $(0,00047 \times v^2) + 70 \text{ N}$ to $(0,00097 \times v^2) + 70 \text{ N}$ for vehicles that are only used on such infrastructure that is adapted for that contact force.
- where v is the maximum vehicle design speed in km/h. The dynamic contact force, F_{mean} , shall be verified according to Section 7 of the standard SS-EN 50317:2012.
- I. The distance between two or more pantographs in fixed and predefined formations of vehicles shall be either 20-30 metres or longer than 40 metres.

A description of the requirements are also to be found in TDOK 2014:0774 [3] and TDOK 2014:0775 [14]. TDOK 2014: 0774 chapters 4.3-4.5 describe which requirements and tests should be set and performed as well as what information the infrastructure manager wishes to receive in order to minimize the risk of electrical interoperability problems. Required data are to be found in "Required vehicle information for power system studies and simulations" [16].

4.9 Towing, lifting/rescue

It must be possible to tow the vehicle with another vehicle equipped with draw gear and buffers in accordance with SS-EN 15566. Vehicles not equipped with draw gear and buffers in accordance with SS-EN 15566 must carry an emergency coupler to enable them to be towed.

The following parameters should be taken into account when designing emergency coupler:

- Weight of emergency coupler [kg].
- Estimated time and conditions for mounting of emergency coupler [min].

- Maximum speed and the conditions that apply when towing the rescue coupler [km/h]. Recommended lowest speed is 30 km/h.
- Ability to connect to the brake systems main pipe.

There shall be instructions for towing and rescuing of the vehicle.

4.10 Other vehicle functions

4.10.1 Vehicles' safety in railway tunnels

- A. If a multiple unit or coach of category B according to Loc&Pas TSI has a permanently installed system to limit and prevent the spread of fire, the system shall, for at least 15 minutes after a fire has started, ensure that fire and smoke are not spread in dangerous concentrations further than 30 metres in spaces intended for passengers or staff. The system's estimated error rate frequency, which means that the spread of heat and fire effluents is not limited, may not exceed $\leq 10^{-7}$ errors/hour. In the estimation of the error rate, error conditions of components, redundancies and software must be included. Consideration may be given to the regular checks and other measures that can be taken.
- B. Vehicles intended for passenger traffic in tunnels longer than 5 kilometres shall be equipped with system for driver to overrule passenger alarm that initiates braking and systems that enable the driver to perceive fire alarms in the train.

4.10.2 Vehicle design for severe winter conditions

- A. For unrestricted access of vehicles on the Swedish network under winter conditions, it shall be demonstrated that the rolling stock meets the following requirements:
 - Temperature zone T2 (-40°C to $+35^{\circ}\text{C}$)
 - Severe snow conditions

When assessing the brake capability of vehicles that are intended to be used in severe snow conditions, if there are no special reasons to do otherwise, a maximum of 60 per cent of the service braking performance of locomotives and railcars shall be credited. At passive transport of locomotives and multiple units as well as for coaches, a maximum of 75 per cent shall be credited.

- B. A vehicle that does not comply with the Loc&Pas TSI shall be designed for operation in a certain temperature range and for operation in certain snow conditions. If the vehicle is designed for operation in severe cold or severe snow conditions, it shall be tested

in accordance with the Technical Report SIS-CEN/TR 16251:2016 (now available as INSTA 851), in applicable parts. The vehicle must be equipped with a snowplough that meets the requirements according to Class S2 in the same report. The brake capability may instead be showed through in-service experience.

Severe cold is be considered to prevail when the temperature is -25°C or lower.

Severe snow conditions are be considered to prevail when snow lies on the track in such an amount that the rail is covered, when snow in the air degrades the visibility or when snow swirls around the vehicle during travel.

Special reasons (see point A above) are be considered to prevail if the vehicle's brake capability has been tested in difficult snow conditions, if the vehicle is equipped with cast iron brake blocks or if in-service experience has shown that the vehicle's brake capability is not significantly impaired in difficult snow conditions.

In-service experience can be if, for example, a Norwegian vehicle has been operating successfully in Norway for 10 years, even without doing any specific tests. It could also be if there is some other experience with the braking system, without the specific vehicle/type being tested. If there is a similar braking system on another, approved vehicle, it can be used as a reference system to demonstrate safety. It assumes that all brake-related parameters are indeed the same.

5 Freight wagons

Applicable requirements for wagons complying with TSI

When authorising wagons that have been assessed by a notified body and complies with the WAG TSI, only 5.7.1 A need to be applied.

Applicable requirements for wagons that have an authorisation from a foreign country

When authorising wagons that have an authorisation from another EU + NO / CH Member State (but not assessed by a notified body against the WAG TSI), only requirement 5.7.1 needs to be applied in addition to the requirements to demonstrate compatibility with the infrastructure, 5.1 - 5.6, see chapter 7.1.

Applicable requirements for wagons that are authorised according to national rules only

When authorising wagons that have neither been assessed by a notified body against the WAG TSI nor have a foreign authorisation that is valid until further notice, they are assessed against national rules only. All the requirements in Chapter 5 apply in applicable parts.

5.1 Detectability in terms of signal safety

The vehicle must comply with the applicable parts of document ERA/ERTMS/033281 [1], and the requirements below.

- A. The distance between two successive axles must be no more than 17.5 metres (a_3 in figure 5.1). However, the distance may be up to 20 metres if the vehicle is only used on such infrastructure that is technically compatible with such a distance between the axles.
- B. The distance between the first and last axle shall be at least 4.5 metres ($L - b_1 - b_2$ in figure 5.1). However, the distance may be down to 3 metres if the vehicle is only used on such infrastructure that is technically compatible with such a distance between the axles.

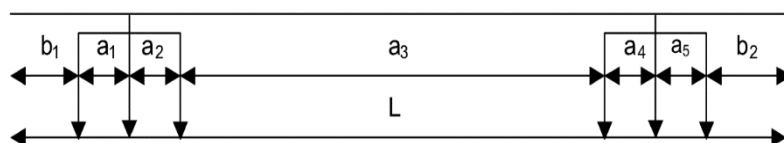

Figure 5.1 Distances between axles

- C. The distance from the outermost axle to the end of the vehicle including buffers may not exceed 4.2 metres.

A half-width of a vehicle including end-throw outward (df) in a curve with a radius of 190 metres may not be larger than the following (where "bi" is the distance from the outermost axle to the vehicle's dimensioning cross section):

$$df \leq 1,93 - 0,206 (b_i - 2,50) \text{ when } 2,50 < b_i \leq 4,20 \text{ m}$$

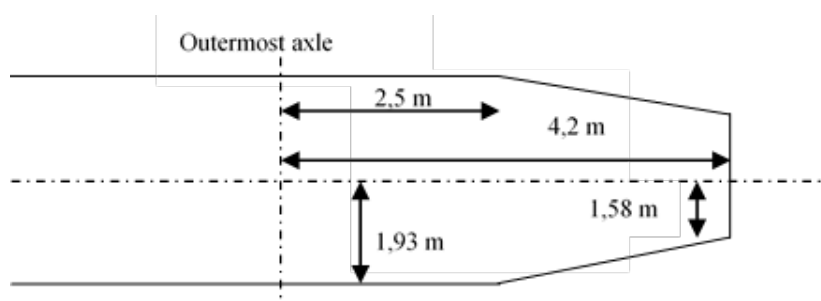

Figure 5.2 Maximum vehicle width including end-throw outside outermost axle.

See also reference [2].

The electrical resistance between the running surfaces of the opposite wheels of a wheelset shall not exceed 0.05 Ω , measured with a voltage between 1.8 V and 2.0 V. The electrical resistance between the running surfaces of the opposite wheels of a wheelset shall be verified according to the method described in TDOK 2014:0776 [4].

The minimum axle load shall be 30 kN for vehicles with brakes acting on the wheels' wear surfaces and 50 kN for other vehicles.

5.2 The infrastructure scanning for railway vehicles

A vehicle must be able to be detected by track-side equipment for axle bearing condition monitoring according to A or be equipped with on-board equipment for axle bearing condition monitoring according to B.

- A. The target area of the vehicle that the track-side equipment is to detect shall be according to Table 5.1. The same applies to the area of the vehicle that shall be free from other heat sources so as not to disturb the detection. Definitions of the parameters in the table shall be according to the standard SS-EN 15437-1:2009 (repealed and replaced by SS-EN 15437-1:2009+A1:2023).

Table 5.1 Target area and area free from other heat sources. The dimensions in the table are given in millimetres. (System 1 = "Servo" and system 2 = "Fues")

Type of track-side equipment	Y_{TA}	W_{TA}	L_{TA}	Y_{PZ}	W_{PZ}	L_{PZ}
System 1	862	≥ 40	Whole	862	≥ 60	≥ 500
System 2	905 ± 20	≥ 40	Whole	905	≥ 100	≥ 500

The requirements on how the vehicle shall be designed for detectability are also described in TDOK2014:0690 [10].

- B. On-board equipment for axle bearing condition monitoring shall be able to detect deteriorations on all of the vehicle's axle bearings and indicate them to the driver

5.3 Dynamic interaction with the track

A vehicle's running dynamic behaviour shall be ensured by applying the standard SS-EN 14363:2016 (repealed and replaced by SS-EN 14363:2016+A2:2022) or by the vehicle's in-service experience from a state within the EEA or from Switzerland on infrastructure with a track gauge width of 1 435 millimetres.

To ensure the running dynamic behaviour of a freight wagon with the maximum permissible axle load above 250 kN and up to 350 kN, the TDOK 2016:0508 [11] shall be applied.

When changing the running dynamic properties for three-axle wagons with short wheelbase, analyses should be made that show how the wagon is affected by track errors at level crossings, see reference [15].

5.4 Dynamic and static profile

The conformity of a vehicle with a reference profile shall be determined according to one of the methods specified in the standard SS-EN 15273-2:2013 (repealed and replaced by SS-EN 15273-2:2013+A1:2016) or by another equivalent method. The vehicle profile must comply with the requirements for dynamic profile SEa or SEc in SS-EN 15273-2:2013 (repealed and replaced by SS-EN 15273-2:2013+A1:2016) or static profile A or C in TDOK 2015:0143 [12]. For vehicles with profile NO1, G1, GA, GB or GC according to SS-EN 15273-2:2013 (repealed and replaced by SS-EN 15273-2:2013+A1:2016) the following apply.

- NO1, G2, G1, GA, GB are housed in Swedish profile SEa.
- GC is housed in Swedish profile SEc.

Specifically for infrastructure managed by Øresundsbro Konsortiet

The vehicle profile must comply with the requirements for GC profiles in SS-EN 15273-2:2013 (repealed and replaced by SS-EN 15273-2:2013+A1:2016). Vehicles with Swedish profile A or SEa fulfil that requirement.

5.5 Electromagnetic compatibility with the environment excluding energy

The vehicle must comply with SS-EN 50121-3-1, SS-EN 50500 and SS-EN 62311. These requirements belong to the Directive of EMC and are not assessed at authorisation. However, conformity shall be stated in the EC declaration of verification.

Vehicles shall fulfil requirements for protection against electric shock according to SS-EN 50153.

5.6 Towing, lifting/rescue

It must be possible to tow the vehicle with another vehicle equipped with draw gear and buffers in accordance with SS-EN 15566. Vehicles not equipped with draw gear and buffers in accordance with SS-EN 15566 must carry an emergency coupler to enable them to be towed.

The following parameters should be taken into account when designing emergency coupler:

- Weight of emergency coupler [kg].
- Estimated time and conditions for mounting of emergency coupler [min].
- Maximum speed and the conditions that apply when towing the rescue coupler [km/h]. Recommended lowest speed is 30 km/h.
- Ability to connect to the brake systems main pipe.

There shall be instructions for towing and rescuing of the vehicle.

5.7 Other vehicle functions

5.7.1 Vehicle design for severe winter conditions

- A. For unrestricted access of vehicles on the Swedish network under winter conditions, it shall be demonstrated that the rolling stock meets the following requirements:
- Temperature zone T2 (-40°C to $+35^{\circ}\text{C}$)
 - Severe snow conditions

When assessing the brake capability of vehicles that are intended to be used in severe snow conditions, if there are no special reasons to do otherwise, a maximum of 75 per cent of the service braking performance of wagons shall be credited.

- B. A vehicle that does not comply with the WAG TSI shall be designed for operation in a certain temperature range and for operation in certain snow conditions. If the vehicle is designed for operation in severe cold or severe snow conditions, it shall be tested in accordance with the Technical Report SIS-CEN/TR 16251:2016 (now available as INSTA 851), in applicable parts. The brake capability may instead be displayed through in-service experience.

Severe cold is be considered to prevail when the temperature is -25°C or lower.

Severe snow conditions are to be considered to prevail when snow lies on the track in such an amount that the rail is covered, when snow in the air degrades the visibility or when snow swirls around the vehicle during travel.

Special reasons (see point A above) are to be considered to prevail if the vehicle's brake capability has been tested in difficult snow conditions, if the vehicle is equipped with cast iron brake blocks or if in-service experience has shown that the vehicle's brake capability is not significantly impaired in difficult snow conditions.

In-service experience can be if, for example, a Norwegian vehicle has been operating successfully in Norway for 10 years, even without doing any specific tests. It could also be if there is some other experience with the braking system, without the specific vehicle/type being tested. If there is a similar braking system on another, approved vehicle, it can be used as a reference system to demonstrate safety. It assumes that all brake-related parameters are indeed the same.

5.7.2 Vehicle structure and mechanical parts

- A. The total weight, weight per axle and weight per wheel of a vehicle shall be determined for the load case with total weight at the highest payload for which the vehicle has been designed.
- B. A vehicle shall be designed so that no cracks or significant permanent deformations or ruptures arise from the loads specified in Section 6 of the standard SS-EN 12663-1:2010 (repealed and replaced by SS-EN 12663-1:2010+A1:2014) for vehicle category L, F-I or F-II. When calculating, the methods in Section 6.2.2.1 of the standard SS-EN 12663-2:2010 shall be used.

5.7.3 Couplings

- A. A coupling system shall be designed so that no person needs to be between the vehicles or units to be connected or disassembled when vehicles or units are moving.
- B. End couplings and inner couplings must be resilient and withstand the forces that arise during operation.
- C. The strength of an inner coupling shall be at least as high as that of the vehicle's end couplings.

5.7.4 Strength of bogie frame

A bogie frame must be designed so that no cracks and no significant permanent deformations or ruptures arise from the load combinations that occur due to

- 1 dynamic forces,
- 2 accelerations and decelerations of the vehicle,
- 3 loading and unloading of goods,
- 4 lifting of the vehicle, and
- 5 bogie-mounted equipment.

The methods in the standard SS-EN 13749:2011 (repealed and replaced by SS-EN 13749:2021) shall be used when calculating the bogie frame strength.

5.7.5 Wheel sets, wheels and axles

- A. A wheelset must transmit forces and torque between the mounted parts. Wheelsets shall be tested according to the methods in standard SS-EN 13260:2009 (repealed and replaced by SS-EN 13260:2020), where limit values for axial force and associated control tests are shown.
- B. A wheel shall transmit forces and torque and resist static, dynamic and thermal loads. Wheels shall be tested according to Sections 6.2 and 7 of standard SS-EN 13979-1:2004 (repealed and replaced by SS-EN 13979-1:2020), where the decision criteria for residual stresses for the evaluation of the tests are shown.
- C. A wheel axle must withstand the transmission of forces and torque and withstand static, dynamic and thermal loads. A wheel axle shall be designed and tested in accordance with Sections 4-6 and be evaluated according to the permitted tension pursuant to the assessment basis in Section 7 of the standard SS-EN 13103:2009 (repealed and replaced by SS-EN 13103-1:2017+A1:2023).

5.7.6 Brake system and brake performance

- A. A vehicle's brake system shall be risk assessed in accordance with Annex 1 to CSM-RA. In the risk assessment, the severity level shall be assessed as catastrophic in cases where a combination of errors causes complete loss of the vehicle's brake capability. A single error shall not cause complete loss of brake capability.
- B. A vehicle's brake system shall be activated automatically in the event of accidental separation of the vehicle from the train or in case of energy loss in the brake control line.
- C. A vehicle's emergency braking capability shall be determined by calculating the stopping distance according to standard SS-EN 14531-1:2016 (repealed and replaced by SS-EN 14531-

1:2015+A1:2018) or according to an equivalent standard. The stopping distance shall be determined by testing.

- D. A vehicle's emergency brake capability can be credited with additions from dynamic brakes and magnetic track brakes. This applies provided that they are included in a safety analysis according to A, which covers the risk of complete loss of the braking power addition after activation of an emergency brake command. The brake capability shall be expressed as brake weight or brake percentage.
- E. A vehicle's parking brake capability without power supply at the load cases specified in 4.7.2 A shall be calculated according to standard SS-EN 14531-1:2016 (repealed and replaced by SS-EN 14531-1:2015+A1:2018) or according to an equivalent standard. The greatest adhesion between wheel and rail that may be assumed in the calculations is 0.15.

6 OTMs and shunters

Applicable requirements for OTMs and shunters complying with TSI

When authorising OTMs and shunters that have been assessed by a notified body and complies with the Loc&Pas TSI, only 6.10.1 A needs to be applied. If the vehicle has a train protection system, then 6.2 shall also be applied.

Applicable requirements for OTMs and shunters that have an authorisation from a foreign country

When authorising OTMs and shunters that have an authorisation from another EU + NO / CH Member State (but not assessed by a notified body against the WAG TSI), only requirement 6.10.1 needs to be applied in addition to the requirements to demonstrate compatibility with the infrastructure, 6.1 - 6.9, see chapter 7.1.

Applicable requirements for OTMs and shunters that are authorised according to national rules only

When authorising OTMs or shunters that have neither been assessed by a notified body against the Loc&Pas TSI or have a foreign authorisation that is valid until further notice, they are assessed against national rules only. All the requirements in Chapter 6 apply in applicable parts.

6.1 Detectability in terms of signal safety

The vehicle must comply with the applicable parts of document ERA/ERTMS/033281 [1], and the requirements below.

- A. The distance between two successive axles must be no more than 17.5 metres (a_3 in figure 6.1). However, the distance may be up to 20 metres if the vehicle is only used on such infrastructure that is technically compatible with such a distance between the axles.
- B. The distance between the first and last axle shall be at least 4.5 metres ($L - b_1 - b_2$ in figure 6.1). However, the distance may be down to 3 metres if the vehicle is only used on such infrastructure that is technically compatible with such a distance between the axles.

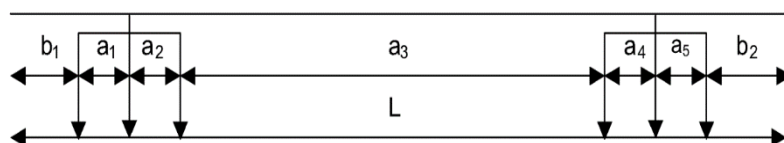

Figure 6.1 Distance between axles

- C. The distance from the outermost axle to the end of the vehicle including buffers may not exceed 4.2 metres.

A half-width of a vehicle including end-throw outward (df) in a curve with a radius of 190 metres may not be larger than the following (where "bi" is the distance from the outermost axle to the vehicle's dimensioning cross section):

$$df \leq 1,93 - 0,206 (b_i - 2,50) \text{ when } 2,50 < b_i \leq 4,20 \text{ m}$$

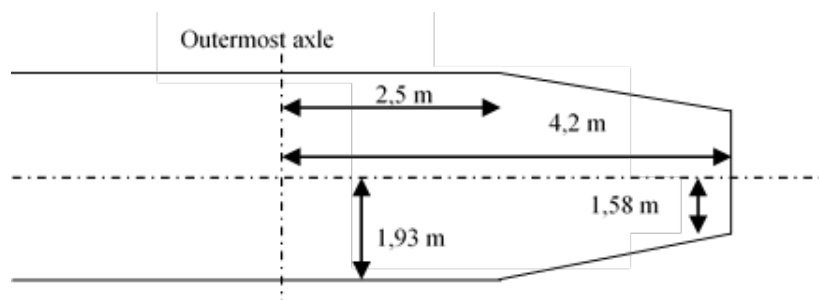

Figure 6.2 Maximum vehicle width including end-throw outside outermost axle.

See also reference [2].

- D. The inrush current shall not exceed 25.0 A measured in the frequency range 0.0-2.0 Hz. During the connection process, the DC component in the inrush current may exceed 45.0 A for a maximum of 1.5 seconds, and it may exceed 25.0 A for a maximum of 2.5 seconds. The currents shall be measured for each combination or

multiple of vehicles. The inrush current shall be verified according to TDOK 2014:0774 [3], annex 1 section 3.2.1.

- E. The electrical resistance between the running surfaces of the opposite wheels of a wheelset shall not exceed 0.05Ω , measured with a voltage between 1.8 V and 2.0 V. The electrical resistance between the running surfaces of the opposite wheels of a wheelset shall be verified according to the method described in TDOK 2014:0776 [4].
- F. The minimum axle load shall be 30 kN for vehicles with brakes acting on the wheels' wear surfaces, including road-rail vehicles with such a brake as a supplementary brake, so-called "putsbroms". For other vehicles, minimum axle load shall be 50 kN.

6.2 Interaction with train protection systems

Vehicles with installed ETCS shall meet the CCS TSI. In addition, for installation of ETCS as well as installation of ATC2/ATCR the requirements A – J below shall be fulfilled in applicable parts. For installations of ATC2 a description how the requirements can be assessed is found in Transportstyrelsen's guideline "ATC-installationer i fordon" [5].

Shunters and OTMs that lack a train protection system must be equipped with a speed limiter and driver's activity control.

- A. The on-board ETCS train protection system shall have at least 30 000 operating hours on average between failures (MTBF) that require isolation of the train protection functions. This shall be shown by a calculation based on accepted methods for operational safety calculation.
- B. For vehicles equipped with type ETCS baseline 2, it shall be shown that
 - 1 the braking curves described in the European Union's Railway Agency document 'Description of the brake curve calculation, EEIG 97E881 version 7A' [6] are implemented in the system, and
 - 2 the system has a monitor according to the current specification for baseline 3 in the European Union's Railway Agency document 'ETCS Driver machine interface, ERTMS 015560', v3.4.0 or v3.6.0 [7].
- C. For vehicles equipped with ETCS and radio remote control, it shall only be possible to use the radio remote control when ETCS on board is in shunting operation mode.

- D. A vehicle equipped with ATC2, ATCR or with STM-function shall have a safety case showing that the onboard system is safely integrated in the vehicle. This safety case shall at least include that the onboard system:
- 1 has been installed correctly based on the conditions for installation of equipment according to the manufacturer's specification,
 - 2 has characteristics and functions that are compatible with the track-side part of ATC2 and/or ATCR.
- E. The STM function shall have features and functions that are compatible with the track-side part of ATC2. It shall be shown that the functional requirements have been developed using the methods described in standards SS-EN 50126, SS-EN 50128 and SS-EN 50129. An STM function intended for ETCS baseline 3 shall meet the requirements of Transportstyrelsen's document STM FRS BVS 544.65001 [8], version 6.1, and STM GRS 100200 E004 TR GRS [9], version 6.1.
- F. A vehicle's interface between the ATC2, ATCR system or the STM function and its service braking system shall be risk assessed in accordance with Annex 1 to CSM-RA. In the risk assessment, the severity level shall be considered critical for the risk that an error or a combination of errors will cause a delay of emergency braking if the service brake is already activated.
- The risk shall be considered as being taken care of if it can be shown that the service brake system, including feedback from the brake to the STM function or the ATC2, ATCR system, has a failure rate of no more than 1×10^{-6} errors per operating hour.
- G. A vehicle equipped with an ATC2, ATCR type train protection system or with an STM function must meet the following requirements for safe integration into the vehicle:
- 1 Traction disconnection shall occur when the ATC2, ATCR system or STM function orders brake.
 - 2 Back feed of the brake must not take place during brake intervention from the ATC2, ATCR system or the STM function.
 - 3 If the vehicle has a performance that makes it possible to accelerate more than 1.5 m/s^2 , there must be an acceleration limitation of at most 1.5 m/s^2 .
 - 4 There must be a brake feedback signal from the braking system to the ATC2, ATCR system or the STM function. This signal

shall be activated by brake intervention due to a pressure drop or a reaction in a brake relay.

- H. The error rate of the STM function shall be less than or equal to 1×10^{-9} error/operating hour for errors that may cause a vehicle speed higher than what the track-side part of ATC2 allows. This shall be shown by a calculation based on accepted methods for calculating acceptable frequencies for safety-critical errors.
- I. The STM function shall have the same functions as the on-board ATC2 system. Deviations or functions that have not been implemented shall be handled in accordance with (EU) 402/2013 CSM-RA either by comparison with reference system or by code of practice so that operational safety is not impaired.
- J. Analyses and tests shall show that the STM function and the track-side part of ATC2 are compatible based on
 - 1 any deviations, restrictions and conditions of the subsystems, as well as
 - 2 the transitions between different types or versions of track-side train protection systems.

6.3 The infrastructure scanning for railway vehicles

A vehicle must be able to be detected by track-side equipment for axle bearing condition monitoring according to A or be equipped with on-board equipment for axle bearing condition monitoring according to B. This does not apply to road-rail vehicles.

- A. The target area of the vehicle that the track-side equipment is to detect shall be according to Table 6.1. The same applies to the area of the vehicle that shall be free from other heat sources so as not to disturb the detection. Definitions of the parameters in the table shall be according to the standard SS-EN 15437-1:2009 (repealed and replaced by SS-EN 15437-1:2009+A1:2023).

Table 6.1 Target area and area free from other heat sources. The dimensions in the table are given in millimetres.(System 1 = "Servo" and system 2 = "Fues").

Type of track-side equipment	Y _{TA}	W _{TA}	L _{TA}	Y _{PZ}	W _{PZ}	L _{PZ}
System 1	862	≥ 40	Whole	862	≥ 60	≥ 500
System 2	905 ± 20	≥ 40	Whole	905	≥ 100	≥ 500

The requirements on how the vehicle shall be designed for detectability are also described in TDOK2014:0690 [10].

- B. On-board equipment for axle bearing condition monitoring shall be able to detect deteriorations on all of the vehicle's axle bearings and indicate them to the driver.

6.4 Communication between the railway vehicle and traffic management

A vehicle with cab shall have a train radio of type GSM-R, which is permanently installed with an external antenna according to specifications in CCS TSI. The train radio shall fulfil GSM-R Baseline 1 according to CCS TSI.

The requirement is that there shall be GSM-R and that it shall fulfil Baseline 1. This requirement shall be reviewed by a designated body. The requirements on the phone and its installation, testing included, is in the CCS TSI. Requirements in the TSI are reviewed by notified bodies.

Derogation can be applied for OTMs and shunters that are only used in such traffic that does not require contact with the infrastructure manager's traffic management.

6.5 Dynamic interaction with the track

A vehicle's running dynamic behaviour shall be ensured by applying the standard SS-EN 14363:2016 (repealed and replaced by SS-EN 14363:2016+A2:2022) or by the vehicle's in-service experience from a state within the EEA or from Switzerland on infrastructure with a track gauge width of 1 435 millimetres.

The running dynamic behaviour of an OTM can be ensured by tests according to the simplified method in the standard SS-EN 14363:2016 (repealed and replaced by SS-EN 14363:2016+A2:2022) or by a simulation according to the standard.

A road-rail vehicle's running dynamic behaviour may be ensured in accordance with Section 5.6 of the standard SS-EN 15746-1:2010 (repealed and replaced by SS-EN 15746-1:2020 and SS-EN 15746-3:2020). In SS-EN 15746-3:2020, the requirements are found in section 5.4.

When changing the running dynamic properties for three-axle vehicles with short wheelbase, analyses should be made that show how the vehicle is affected by track errors at level crossings, see reference [15].

6.6 Dynamic and static profile

The conformity of a vehicle with a reference profile shall be determined according to one of the methods specified in the standard SS-EN 15273-2:2013 (repealed and replaced by SS-EN 15273-2:2013+A1:2016) or by another equivalent method. The vehicle profile must comply with the requirements for dynamic profile SEa or SEc in SS-EN 15273-2:2013 (repealed and replaced by SS-EN 15273-2:2013+A1:2016) or static profile A or C in TDOK 2015:0143 [12]. For vehicles with profile NO1, G1, GA, GB or GC according to SS-EN 15273-2:2013 (repealed and replaced by SS-EN 15273-2:2013+A1:2016) the following apply.

- NO1, G2, G1, GA, GB are housed in Swedish profile SEa.
- GC is housed in Swedish profile SEc.

Specifically for infrastructure managed by Øresundsbro Konsortiet

The vehicle profile must comply with the requirements for GC profiles in SS-EN 15273-2:2013 (repealed and replaced by SS-EN 15273-2:2013+A1:2016). Vehicles with Swedish profile A or SEa fulfil that requirement.

6.7 Electromagnetic compatibility with the environment excluding energy

The vehicle must comply with SS-EN 50121-3-1, SS-EN 50500 and SS-EN 62311. These requirements belong to the Directive of EMC and are not assessed at authorisation. However, conformity shall be stated in the EC declaration of verification.

Additional requirements for vehicles with pantographs are to be found in chapter 4.8. Vehicles without pantograph shall fulfil requirements for protection against electric shock according to SS-EN 50153.

6.8 Current collection and interaction with the infrastructure energy system

Requirements according to chapter 4.8.

6.9 Towing, lifting/rescue

It must be possible to tow the vehicle with another vehicle equipped with draw gear and buffers in accordance with SS-EN 15566. Vehicles not equipped with draw gear and buffers in accordance with SS-EN 15566 must carry an emergency coupler to enable them to be towed.

The following parameters should be taken into account when designing emergency coupler:

- Weight of emergency coupler [kg].

- Estimated time and conditions for mounting of emergency coupler [min].
- Maximum speed and the conditions that apply when towing the rescue coupler [km/h]. Recommended lowest speed is 30 km/h.
- Ability to connect to the brake systems main pipe.

There shall be instructions for towing and rescuing of the vehicle.

6.10 Other vehicle functions

6.10.1 Vehicle design for severe winter conditions

- A. For unrestricted access of vehicles on the Swedish network under winter conditions, it shall be demonstrated that the rolling stock meets the following requirements:
 - Temperature zone T2 (-40°C to $+35^{\circ}\text{C}$)
 - Severe snow conditions
- B. When assessing the brake capability of vehicles that are intended to be used in severe snow conditions, if there are no special reasons to do otherwise, a maximum of 60 per cent of the service braking performance of OTMs and shunters shall be credited. At passive transport of the vehicles, a maximum of 75 per cent shall be credited.
- C. A vehicle that does not comply with the Loc&Pas TSI shall be designed for operation in a certain temperature range and for operation in certain snow conditions. If the vehicle is designed for operation in severe cold or severe snow conditions, it shall be tested in accordance with the Technical Report SIS-CEN/TR 16251:2016 (now available as INSTA 851), in applicable parts. The vehicle must be equipped with a snowplough that meets the requirements according to Class S2 in the same report. The brake capability may instead be displayed through in-service experience.

Severe cold is be considered to prevail when the temperature is -25°C or lower.

Severe snow conditions are be considered to prevail when snow lies on the track in such an amount that the rail is covered, when snow in the air degrades the visibility or when snow swirls around the vehicle during travel.

Special reasons (see point A above) are be considered to prevail if the vehicle's brake capability has been tested in difficult snow conditions, if the vehicle is equipped with cast iron brake blocks or if in-service experience

has shown that the vehicle's brake capability is not significantly impaired in difficult snow conditions.

In-service experience can be if, for example, a Norwegian vehicle has been operating successfully in Norway for 10 years, even without doing any specific tests. It could also be if there is some other experience with the braking system, without the specific vehicle/type being tested. If there is a similar braking system on another, approved vehicle, it can be used as a reference system to demonstrate safety. It assumes that all brake-related parameters are indeed the same.

6.10.2 Vehicle structure and mechanical parts

- A. The total weight, weight per axle and weight per wheel of a vehicle shall be determined for the load cases
 - 1 total weight in operating condition (weight of the vehicle and the driver and all consumables loaded to the maximum), and
 - 2 total weight at the highest payload for which the vehicle has been designed.
- B. A vehicle shall be designed so that no cracks or significant permanent deformations or ruptures arise from the loads specified in Section 6 of the standard SS-EN 12663-1:2010 (repealed and replaced by SS-EN 12663-1:2010+A1:2014) for vehicle category L, F-I or F-II. This applies to road-rail vehicles only if they are intended to be included in a train. When calculating, the methods in Sections 6 and 7 of the standard SS-EN 12663-1:2010 (repealed and replaced by SS-EN 12663-1:2010+A1:2014) or Section 6.2.2.1 of the standard SS-EN 12663-2:2010 shall be used.

6.10.3 Couplings

- A. A coupling system shall be designed so that no person needs to be between the vehicles or units to be connected or disassembled when vehicles or units are moving.
- B. End couplings and inner couplings must be resilient and withstand the forces that arise during operation.
- C. The strength of an inner coupling shall be at least as high as that of the vehicle's end couplings.

6.10.4 Strength of bogie frame

A bogie frame must be designed so that no cracks and no significant permanent deformations or ruptures arise from the load combinations that occur due to

- 1 dynamic forces,
- 2 accelerations and decelerations of the vehicle,
- 3 loading and unloading of goods,
- 4 lifting of the vehicle, and
- 5 bogie-mounted equipment.

The methods in the standard SS-EN 13749:2011 (repealed and replaced by SS-EN 13749:2021) shall be used when calculating the bogie frame strength. For road-rail vehicles, standard SS-EN 15746-1:2010 (repealed and replaced by SS-EN 15746-3:2020) shall be used.

6.10.5 Wheel sets, wheels and axles

- A. A wheelset must transmit forces and torque between the mounted parts. Wheelsets shall be tested according to the methods in standard SS-EN 13260:2009 (repealed and replaced by SS-EN 13260:2020), where limit values for axial force and associated control tests are shown. For road-rail vehicles, standard SS-EN 15746-1:2010 (repealed and replaced by SS-EN 15746-3:2020) shall be used.
- B. A wheel shall transmit forces and torque and resist static, dynamic and thermal loads. Wheels shall be tested according to Sections 6.2 and 7 of standard SS-EN 13979-1:2004 (repealed and replaced by SS-EN 13979-1:2020), where the decision criteria for residual stresses for the evaluation of the tests are shown. For road-rail vehicles, standard SS-EN 15746-1:2010 (repealed and replaced by SS-EN 15746-3:2020) shall be used.
- C. A wheel axle must withstand the transmission of forces and torque and withstand static, dynamic and thermal loads. A non-powered wheel axle shall be designed and tested in accordance with Sections 4-6 and be evaluated according to the permitted tension pursuant to the assessment basis in Section 7 of the standard SS-EN 13103:2009 (repealed and replaced by SS-EN 13103-1:2017+A1:2023). A powered wheel axle shall be designed and tested according to Sections 4-6 and be evaluated according to the permitted tension pursuant to the assessment basis in Section 7 of the standard SS-EN 13104:2009 (repealed and replaced by SS-EN 13103-1:2017+A1:2023). For road-rail vehicles, standard SS-EN 15746-1:2010 (repealed and replaced by SS-EN 15746-3:2020) shall be used.

6.10.6 Windscreen

A windscreen in a driver's cab shall resist the forces of a collision with a cylindrical object weighing 1 000 grams and having a hemispherical end. The screen shall withstand the forces of the collision in such a way that

- 1 the object does not penetrate it,
- 2 it does not shatter, and
- 3 it remains within its frame.

The windscreen shall be tested according to Section 6.1.4 of standard SS-EN 15152:2019 or according to an equivalent standard.

These requirements do not apply to road-rail vehicles.

6.10.7 Brake system and brake performance

Requirements in A – G do not apply to road-rail vehicles whose braking system only brakes the wheels intended for road traffic and which runs on the rails. For other road-rail vehicles J – G do not apply.

- A. A vehicle's brake system shall be risk assessed in accordance with Annex 1 to CSM-RA. In the risk assessment, the severity level shall be assessed as catastrophic in cases where a combination of errors causes complete loss of the vehicle's brake capability. A single error shall not cause complete loss of brake capability.
- B. A vehicle's brake system shall be activated automatically in the event of accidental separation of the vehicle from the train or in case of energy loss in the brake control line.
- C. A vehicle's emergency braking capability shall be determined by calculating the stopping distance according to standard SS-EN 14531-1:2016 (repealed and replaced by SS-EN 14531-1:2015+A1:2018) or according to an equivalent standard. The stopping distance shall be determined by testing.
- D. A vehicle's emergency brake capability can be credited with additions from dynamic brakes and magnetic track brakes. This applies provided that they are included in a safety analysis according to A, which covers the risk of complete loss of the braking power addition after activation of an emergency brake command. The brake capability shall be expressed as brake weight or brake percentage.
- E. A vehicle's parking brake capability without power supply at the load cases specified in 5.10.2 A p2 shall be calculated according to standard SS-EN 14531-1:2016 (repealed and replaced by SS-EN 14531-1:2015+A1:2018) or according to an equivalent standard. The

greatest adhesion between wheel and rail that may be assumed in the calculations is 0.15.

- F. At least two independent emergency brake command devices shall be available in the driver's cab. Each of these shall be able to be activated by a simple and individual action by the driver during normal driving position. One of these devices shall be a red mushroom push button.

The emergency brake position of the devices must be mechanically self-locking. Unlocking this mode shall not be possible to do by mistake.

- G. It shall be possible to determine from the driver's cab the status of the
- 1 brake system parts that can be controlled or shut off individually,
 - 2 brake energy supply,
 - 3 dynamic brake, if included in the braking capacity according to D, and
 - 4 brake system that is connected to the traction system, if the brake system is included in the brake capability according to D.

6.10.8 Fire safety

A vehicle's fire safety shall be risk assessed in accordance with Appendix 1 to CSM-RA.

A vehicle shall be dimensioned and designed so that the driver and staff on board are protected from catastrophic consequences of fire. This shall be done based on materials, products, components and systems participation and behaviour in the event of fire.

These requirements do not apply to shunters and road-rail vehicles.

6.10.9 Driver's cab

- A. A vehicle with a driver's cab shall be designed so that the driver can easily see the relevant information displayed in the form of signals and safety-related signs along the track. A vehicle with a driver's cab shall be designed in accordance with standard SS-EN 16186-1:2014 (repealed and replaced by SS-EN 16186-1:2014+A1:2018).
- B. The driver cab's lighting and the lighting of instruments must not emit green light, with the exception of the light that the train protection system equipment emits. This does not apply to road-rail vehicles.
- C. A vehicle with a driver's cab must be equipped with a speedometer.

6.10.10 External lights & visible and audible warning devices

External lights

- 1A. The colour green shall not be used for external light or illumination; this requirement is made to prevent any confusion with fixed signals.

Headlights

This clause applies to units fitted with a driver's cab.

- 2A. Two white headlamps shall be provided at the front end of the train in order to give visibility for the train driver.

- 2B. These head lamps shall be located:

- at the same height above the rail level, with their centres between 1 500 and 2 000 mm above the rail level.
- symmetrically compared to the centre-line of rails, and with a distance between their centres not less than 1 000 mm.

- 2C. The colour of the head lamps shall be in accordance with the values specified in the specification referenced in SS-EN 15153-1:2020, clause 5.3.3, table 1.

- 2D. Headlamps shall provide 2 luminous intensity levels: 'dimmed headlamp' and 'full-beam headlamp'.

For 'dimmed headlamp', the luminous intensity of headlamps measured along the optical axis of the head lamp shall be in accordance with the values specified in the specification referenced in SS-EN 15153-1:2020, clause 5.3.4, table 2, first line.

For 'full-beam headlamp', the minimum luminous intensity of headlamps measured along the optical axis of the lamp shall be in accordance with the values specified in the specification referenced in SS-EN 15153-1:2020, index 38, clause 5.3.4, Table 2, first line.

- 2E. The installation of head lamps on the unit shall provide a means of alignment adjustment of their optical axis when installed on the unit according to the specification referenced in SS-EN 15153-1:2020, clause 5.3.5.

- 2F. Additional headlamps may be provided (e.g. upper headlamps). These additional headlamps shall fulfil the requirement on the colour of head lamps specified above in this clause.

Marker lights

This clause applies to units fitted with a driver's cab.

- 3A. Three white marker lamps shall be provided at the front end of the train in order to make the train visible.
- 3B. Two lower marker lamps shall be located:
- at the same height above the rail level, with their centres between 1 500 and 2 000 mm above the rail level.
 - symmetrically compared to the centre-line of rails, and with a distance between their centres not less than 1 000 mm.
- 3C. The third marker lamp shall be located centrally above the two lower lamps, with a vertical separation between their centres equal to or greater than 600 mm.
- 3D. It is permitted to use the same component for both headlights and marker lights.
- 3E. The colour of marker lamps shall be in accordance with the values specified in the specification referenced in SS-EN 15153-1:2020, clause 5.4.3.1, Table 4.
- 3F. The spectral radiation distribution of light from the marker lamps shall be in accordance with the values specified in the specification referenced in SS-EN 15153-1:2020, clause 5.4.3.2.
- 3G. The luminous intensity of marker lamps shall be in accordance with the specification referenced in SS-EN 15153-1:2020, clause 5.4.4, Table 6.

Tail lights

- 4A. Two red tail lamps shall be provided at the rear end of units intended to be operated at the rear end of the train in order to make the train visible.
- 4B. For units without driver's cab assessed for general operation, the lamps may be portable lamps or be replaced by reflective plates. For portable lamps/plates, the lamp/plate shall be suitable for attaching to units that comply with the provisions regarding fasteners and free space according to figure 11 in SS-EN 16116-2:2021. A lamp shall be equipped with the following:
- A switch (on/off).
 - A warning light indicating the battery status.
- 4C. The tail lamps shall be located:
- at the same height above the rail level, with their centres between 1 500 and 2 000 mm above the rail level.

- symmetrically compared to the centre-line of rails, and with a distance between their centres not less than 1 000 mm.

4D. The colour of tail lamps shall be in accordance with the specification referenced in SS-EN 15153-1:2020, clause 5.5.3, Table 7.

4E. The luminous intensity of tail lamps shall be in accordance with the specification referenced in SS-EN 15153-1:2020, clause 5.5.4, Table 8.

4F. The plates reflective section shall be at least 150 by at least 200 mm. The side triangles shall be white, the top and the bottom triangles shall be red. The plate shall be retro-reflective in accordance with EN 12899-1:2007 Class Ref. 2.

Light controls

This clause applies to units fitted with a driver's cab.

5A. It shall be possible for the driver to control

- the head and marker lamps of the unit from the normal driving position,
- the tail lamps of the unit from the cab.

This control may use independent commands or a combination of commands.

Horn (audible warning device)

This clause applies to units fitted with a driving cab.

6A. The notes of the audible warning horns shall be recognisable as coming from a train and not be similar to warning devices used in road transport or as factory or other common warning devices. The operation of the warning horns shall emit at least one of the following separate warning sounds below:

- Sounding 1: the fundamental frequency of the separately sounded note shall be 660 Hz \pm 30 Hz (high note).
- Sounding 2: the fundamental frequency of the separately sounded note shall be 370 Hz \pm 20 Hz (low note).

6B. In case additional warning sounds to one of the above (separate or combined) are provided on a voluntary basis, their sound pressure level shall not be higher than values specified below in 6C.

6C. The C weighted sound pressure level produced by each horn sounded separately (or in a group if designed to sound

simultaneously as a chord) when integrated on the unit shall be as defined in the specification referenced in SS-EN 15153-2:2020.

The conformity assessment procedure is specified in SS-EN 15153-2:2020.

6D. Warning horns and their control systems shall be designed or protected, so far as is practicable, to maintain their function when impacted by airborne objects such as debris, dust, snow, hail or birds.

6E. It shall be possible for the driver to sound the audible warning device from all driving positions.

6.10.11 Radio remote for shunting operation

- A. A vehicle's radio remote control equipment for shunting operation shall be risk assessed in accordance with Appendix 1 to CSM-RA. In the risk assessment, the severity level shall be assessed as critical if there is a risk that the radio remote control equipment will be disturbed or that the radio contact between the vehicle and the radio transmitter will be lost.
- B. The vehicle shall have a function that automatically brake to a stop in the event of loss of radio contact when the predetermined time limit of the system is exceeded.
- C. The radio remote control equipment's control unit must be designed in such a way that it prevents accidental traction initiation or release of the brake.

6.10.12 Noise

OTMs and shunters shall comply with the provisions on limit values for stationary noise, starting noise, pass-by noise or noise in the driver's cab according to A – D below. This does not apply to road-rail vehicles.

The limit values must be verified by a test according to the standard ISO 3095:2013. However, the limit value for pass-by noise does not need to be verified for shunters or for OTMs equipped with composite brake blocks or disc brakes.

A. Stationary noise

The limit values for the following sound pressure levels under normal vehicle conditions concerning the stationary noise are set out in Table 6.2.

- 1 the A-weighted equivalent continuous sound pressure level of the unit ($L_{pAeq, T}$ [unit]).
- 2 the A-weighted equivalent continuous sound pressure level at the nearest measuring position i considering the main air compressor ($L_{ipAeq, T}$).
- 3 the AF-weighted sound pressure level at the nearest measuring position i considering impulsive noise of the exhaust valve of the air dryer ($L_{ipAFmax}$).

The limit values are defined at a distance of 7,5 m from the centre of the track and 1,2 m above top of rail.

Table 6.2 Limits values for stationary noise.

Categories of the rolling stock subsystem	$L_{pAeq, T}$ [unit] [dB]	$L_{ipAeq, T}$ [dB]	$L_{ipAFmax}$ [dB]
Shunters and OTMs with electric traction	70	75	85
Shunters and OTMs with diesel traction	71	78	

B. Starting noise

The limit values for the AF-weighted maximum sound pressure level ($L_{pAF, max}$) concerning the starting noise are set out in Table 6.3.

The limit values are defined at a distance of 7,5 m from the centre of the track and 1,2 m above top of rail.

Table 6.3 Limit values for starting noise.

Categories of the rolling stock subsystem	$L_{pAF, max}$ [dB]
Shunters (electric) with total tractive power $P < 4500$ kW	81
Shunters (electric) with total tractive power $P \geq 4500$ kW OTMs with electric traction	84
Shunters (diesel) $P < 2000$ kW at the engine output shaft	85
Shunters (diesel) $P \geq 2000$ kW at the engine output shaft OTMs with diesel traction	87

C. Pass-by noise

The limit values for the A-weighted equivalent continuous sound pressure level at a speed of 80 km/h ($L_{pAeq, Tp, (80 \text{ km/h})}$) concerning the pass-by noise are set out in Table 6.4.

The limit values are defined at a distance of 7,5 m from the centre of the track and 1,2 m above top of rail.

Table 6.4 Limits for pass by noise.

Categories of the rolling stock subsystem	$L_{pAeq, Tp, (80 \text{ km/h})}$ [dB]
Shunters and OTMs with electric traction	84
Shunters and OTMs with diesel traction	85
OTMs without traction	83

D. Driver's cab interior noise

The limit values for the A-weighted equivalent continuous sound pressure level ($L_{pAeq, T}$) concerning the noise within the driver's cab of shunters and OTMs are set out in Table 6.5.

The limit values are defined in the vicinity of the driver's ear.

Table 6.5 Limit values for driver's cab interior noise.

Noise within the driver's cab	$L_{pAeq, Tp, (80 \text{ km/h})}$ [dB]
At standstill with horns sounding	95
At maximum speed	78

7 Regulation TSFS 2022:36 §§ 1 – 8

7.1 TSFS 2022:36 §§ 1 – 3, scope

Regulation TSFS 2022:36 applies to the authorisation of new vehicles, rebuilt/modernised vehicles and when foreign vehicles shall extend the area of use to Sweden.

Vehicles that comply with Loc&Pas TSI or WAG TSI only need to meet a limited number of requirements in addition to the requirements in the TSD. OTM's that have chosen to only meet national requirements and freight wagons that are outside the scope of application of WAG TSI, need to meet all requirements applicable to the vehicle category in the regulation. These are stated in the introduction of the respective chapters in this supplementary information.

Foreign vehicles (authorised under Directive 2008/57) which are to extend the area of use to Sweden shall meet requirements according to chapter 7.1.4 of Loc&Pas TSI or 7.2.2.4 of WAG TSI and, if applicable, chapter 7.4.2.4 of CCS TSI (7.4.2.3 in version from 2023). Guidance from ERA, ERA1209-099 [17], also applies to OTMs. Foreign OTMs that are authorised under directive 2016/797 shall meet all applicable requirements in the regulation when they are to extend the area of use to Sweden.

7.2 TSFS 2022:36 §§ 4 – 5, Rebuilding and modernisation

7.2.1 Vehicles in the scope of TSI Loc&Pas or TSI WAG

When rebuilding vehicles in the scope of Loc&Pas TSI or WAG TSI, new authorisation is regulated according to the limit values stated in ch. 7 in the respective TSI (Loc&Pas TSI, WAG TSI and CCS TSI). This applies to the requirements in the TSIs.

For the national requirements, it is only the national requirements for control-command and signalling that may require new authorisation, i.e. the requirements in ch. 4.2 and 6.2. New authorisation is required if the change affects any of the requirements on control-command and signalling (chapters 4.2 and 6.2), except for changes that do not affect the basic design characteristics. For these changes, authorisation is not required if all of the following 9 conditions are met:

- (1) The target functionality remains unchanged or is set to the state already expected during the original certification or authorisation procedure.
- (2) The interfaces relevant for safety and technical compatibility remain unchanged or are set to the state already expected during the original certification or authorisation procedure.
- (3) The result of the safety assessment (eg the safety case according to EN 50126) remains unchanged.
- (4) No new Safety Related Application Conditions (SRAC) or interoperability restrictions have been added due to the change.
- (5) An assessment body, according to CSM-RA, has independently assessed the applicant's risk assessment and therein the evidence that the change does not adversely affect safety. The applicant's evidence must include evidence that the change does in fact correct the causes of the original functionality deviation.
- (6) The change is carried out according to a quality management system approved according to relevant modules in the Swedish Transport Agency's regulations TSFS 2022:40.
- (7) The individual configuration management defines a "system identifier" (as defined in clause 9) and the functional part has not changed after the change.
- (8) The change shall be part of the configuration management required by Article 5 of Regulation (EU) 2018/545.
- (9) A "system identifier", "function identifier" and a "realisation identifier" must be determined by each individual supplier.

A "system identifier" is a numbering scheme for identifying the system version of a control-command and signalling subsystem and distinguishing between a function identifier and a realisation identifier.

A "functional identifier" is a part of the system identifier and consists of a number or a number of numbers established by the individual configuration management, which provides a reference to the basic design characteristics of control-command and signalling of a control-command and signalling subsystem.

A "realisation identifier" is part of the system identifier and consists of a number or a number of numbers established by the individual configuration management of a supplier, which constitutes a specific configuration (eg HW or SW) of a control-command and signalling subsystem.

7.2.2 OTMs and freight wagons that are authorised according to national requirements

To see if a new authorisation is required for OTMs and freight wagons that are authorised according to national requirements, the limit values in table 17a of Loc&Pas TSI and table 11a of WAG TSI respectively, shall be applied to the national requirements in the corresponding areas.

For OTMs that have a train protection system, the national requirements for control-command and signalling shall be handled as described in ch. 7.2.1.

The process according to Article 15 and/or 16 of Regulation (EU) 2018/545 [18] shall be followed.

Regardless of whether a new authorisation is required or not, the national requirements must be met after a rebuilding or modernisation. However, they are only applicable to the parts that are rebuilt or modernised.

7.3 TSFS 2022:36 §§ 7 – 8, Verification procedure

7.3.1 Assessment

A designated body (which is the one who shall assess against the requirements of the regulation) shall carry out its assessment according to one or more of the modules specified in the regulation. The modules are described in TSFS 2022:40 [19].

7.3.2 Documentation

In order for OTMs and freight wagons that are assessed against national rules to be considered to meet the essential requirements, the applicant should present the required documentation (see ch. 4.2.12 of TSI Loc&Pas and 4.4 and 4.5 of TSI WAG respectively).

The following documentation should be attached to an application:

1) Lifting and rerailing, instructions stating:

- Procedures for the use of rescue measures and associated necessary precautions to be taken, e.g. use of emergency exits, access to rolling stock for rerailing, disengagement of brakes, electrical grounding, towing,

- The effects when the described emergency measures are taken, e.g. reduction in braking performance after disengagement of brakes.

2) Technical information about the vehicle and its intended use.

3) Maintenance instructions for the vehicle in the user's language. Maintenance manual.

4) Maintenance plan for the vehicle.

5) Driver's manual for the vehicle in Swedish (the user's language).

8 Administration

Section Railway Engineering, Road and Railway.

9 References

- | | | |
|-----|---|---------------|
| [1] | Interfaces between Control-Command and Signalling trackside and other subsystems (ERA/ERTMS/033281) | era.europa.eu |
| [2] | Utredning om kollisionrisk mellan fordon i växlar på grund av långt buffertövershång i kombination med kort avstånd mellan hindersfrihetspunkt och isolerskarv, F08-13349/TR60 (2009-06-11) | * |
| [3] | TDOK 2014:0774 "BVS 543.19300 - Elektriska krav på fordon med avseende på kompatibilitet med infrastrukturen och andra fordon" (2010-02-05) | * |
| [4] | TDOK 2014:0776 "BVS 544.14002 - Krav för säker kortslutning av spårledning" (2010-03-15) | * |
| [5] | Transportstyrelsen's guideline "ATC-installationer i fordon" | * |

- | | | |
|------|--|--|
| [6] | ”Description of the brake curve calculation, EEIG 97E881 version 7A” | era.europa.eu |
| [7] | ”ETCS Driver machine interface, ERTMS 015560” | era.europa.eu |
| [8] | STM FRS BVS 544.65001, version 6.1, ”ATC2-STM Functional requirements specification with national & additional requirements” (2017-05-12) | * |
| [9] | STM GRS 100200 E004 TR GRS, version 6.1, ”GRS STM General technical requirements specification (2017-05-12) | * |
| [10] | TDOK 2014:0690 ”BVS 1592.0201 - Detektorer - Förutsättningar för varmgångs- och tjuvbromsdetektering av järnvägsfordon” (2008-07-01) | * |
| [11] | TDOK 2016:0508 ”Gångdynamiska förutsättningar för trafik med axellaster upp till och med 35 ton” (2016-10-21) | * |
| [12] | TDOK 2015:0143 ”Fordonsprofiler, Dimensionering av järnvägsfordons yttermått” (2015-04-24) | * |
| [13] | Bekendtgørelse om køretøjers tekniske kompatibilitet med jernbanenettet, BEK nr 1465 af 05/12/2016 | trafikstyrelsen.dk |
| [14] | TDOK 2014:0775 ”BVS 543.330 - Krav på strömvtagare och interaktionen mellan strömvtagaren och kontaktledningen” (2007-10-23) | * |
| [15] | Slutrapport RJ 2019:02 – Urspårning med tåg 5678 i Ludvika, Dalarnas län, den 12 oktober 2017 (Diariern J-22/17, 2019-03-27) | havkom.se |
| [16] | Required vehicle information for power system studies and simulations | * |
| [17] | ERA1209-099 Clarification about applicability of clause 7.1.4 of LOCPAS TSI to special vehicles such as On Track Machines | era.europa.eu |
| [18] | KOMMISSIONENS GENOMFÖRANDEFÖRORDNING (EU) 2018/545 av den 4 april 2018 om fastställande av praktiska arrangemang i processen för godkännande av järnvägsfordon och typer av järnvägsfordon enligt Europaparlamentets och rådets direktiv (EU) 2016/797 | era.europa.eu |
| [19] | TSFS 2022:40 Transportstyrelsens föreskrifter om kontrollmoduler för EG-kontroll av nationella regler för fordon och fasta installationer | * |

*Documents can be found on Transportstyrelsen.se